

CROWN WAV 50-84 MAN-UP ORDER PICKER

Price - £ 5500



General Information :

1. Manufacturer		Crown Equipment Corporation
2. Model		WAV 50-84
3. Power		Electric 24 Volts
4. Vehicle Capacities	Operator Compartment	135 kg
	Load Tray	45 kg
	Load Deck	115 kg
	with Battery	512 kg
5. Vehicle Weight		280 mm
6. Platform Step Height		2135 mm
7. Platform Lift Height		

Dimensions :

8. Load Tray Height [load tray is 178mm below top of restraint rail] (with tray in highest position)	Platform fully lowered	1145 mm
	Platform fully raised	3000 mm
9. Overall Extended Height		3175 mm
10. Reach Height		4100 mm
11. Overall Collapsed Height		1320 mm
12. Vehicle Length		1525 mm
13. Vehicle Width		750 mm
14. Vehicle Width	with Rail Guide Rollers	890 mm
	Rail Guide Wheel Height (top)	65 mm
	Rail Guide Wheel Diameter	65 mm
	Rail Guide Wheel Thickness	25 mm
15. Drive Wheels (d x w)	Poly	(2) 305x65 mm
Castor Wheels (d x w)	Poly	(2) 255x65 mm

Performance :

16. Minimum Turning Radius		1205 mm
17. Lift Speeds		0.30 m/sec
18. Lower Speeds		0.25 m/sec
19. Service Brakes		Regenerative
20. Parking Brake		Electric Released/Spring Applied
21. Grade Clearance		15 %
22. Travel Speeds		(see below)

Battery :

23. Batteries	Maintenance free	195 Ah
24. Charger	Standard	25 Amp



CROWN WAV 50-84 MAN-UP ORDER PICKER

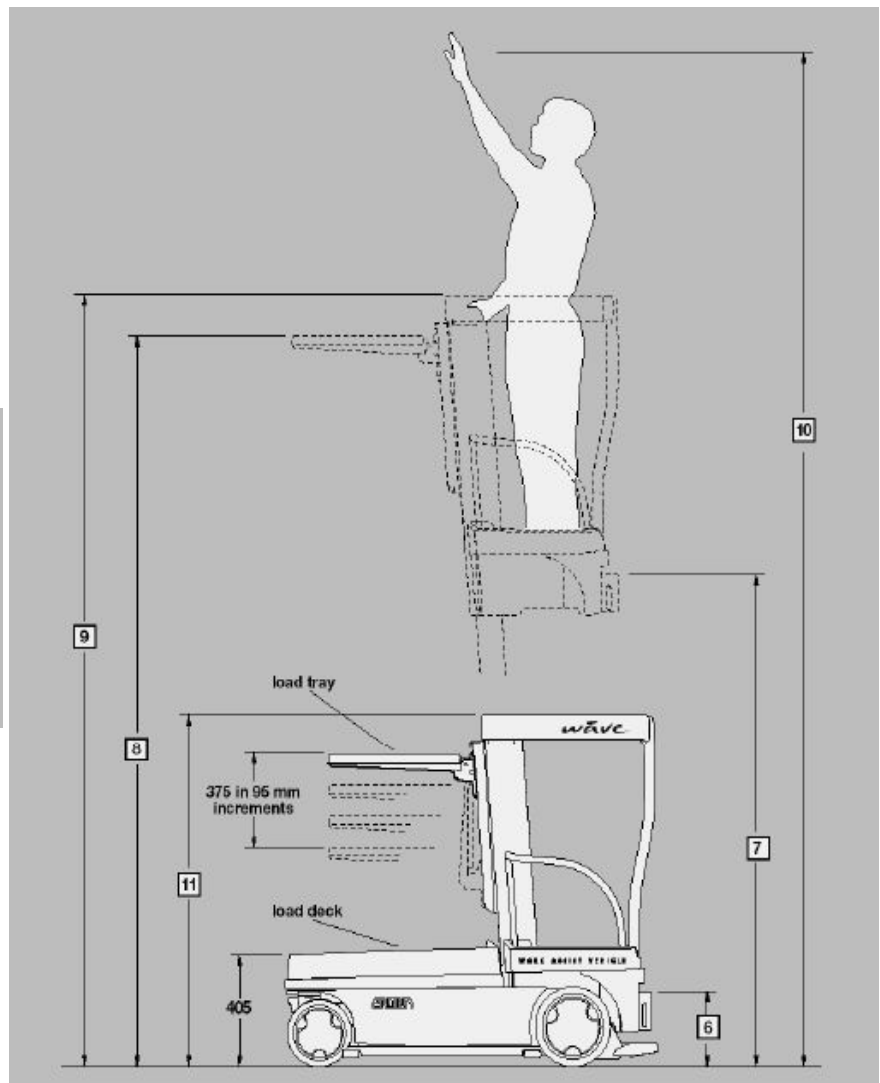
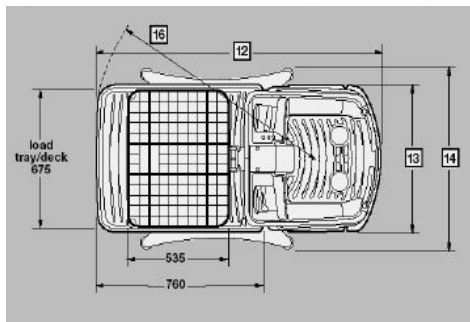

Top Travel Speeds (km/h)

<u>Platform Height</u>	<u>Gate Condition</u>	<u>Directions</u>	
		<u>Forward</u> Speed	<u>Reverse</u> Speed
Below 510	Open	6.0	3.2
Below 510	Closed	4.0	3.2
510 to 2135	Open	0.0	0.0
510 to 2135	Closed	3.2	3.2

Floor Loading - Laden (135kg operator, 115kg load deck, 90kg load tray)

	Load (kg)	Pressure (kg/cm ²)
Front Castor Wheel	169	26
Rear Drive Wheel	258	20

